

# 52CX Pitts manual

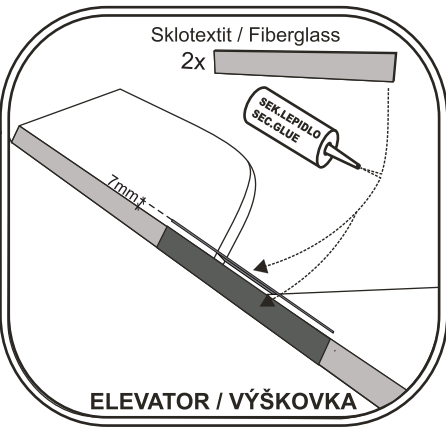

- Obě pohyblivé části výškovky spojíme zalepením sklotextit. obdelníků, výškovku vsuneme do výřezu, zkontrolujeme rovinu a zalepíme.
- Both moving parts of the elevator put together by fiberglass rectangles. This elevator insert into the fuselage cutout, check that the empennage is parallel to the respective planes and glue up.

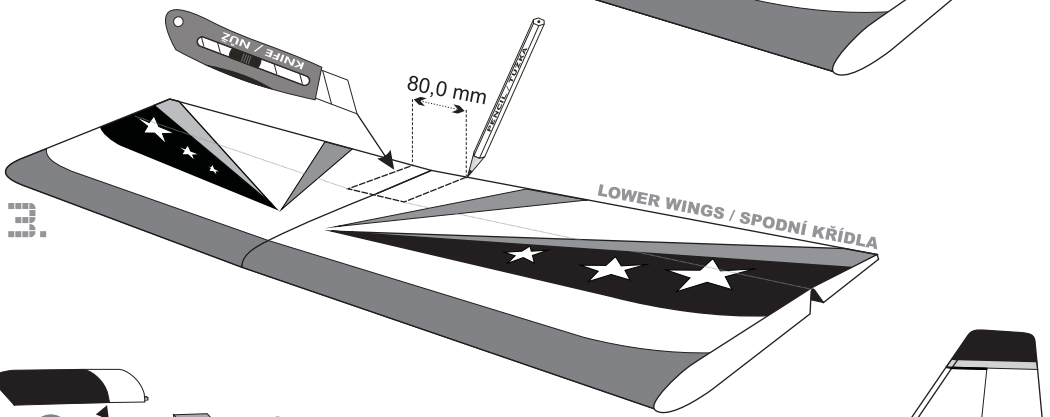
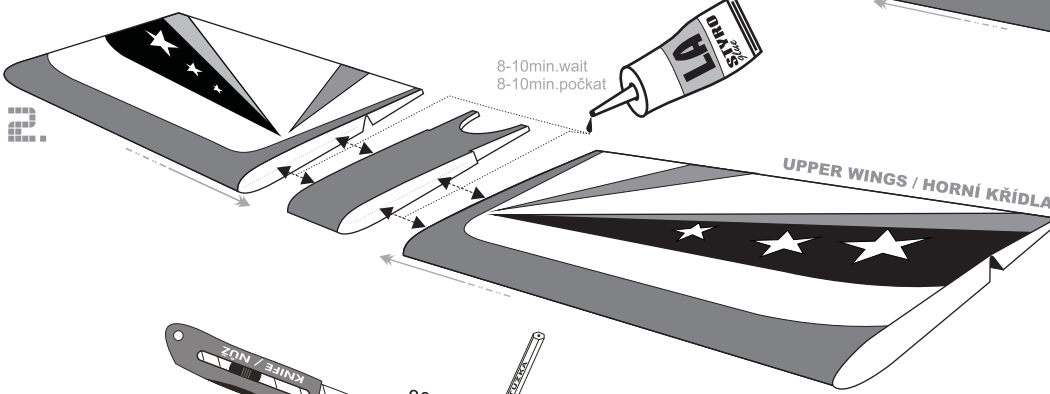
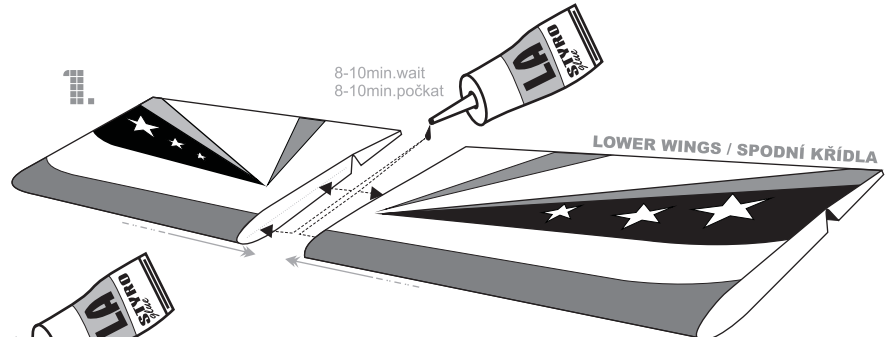
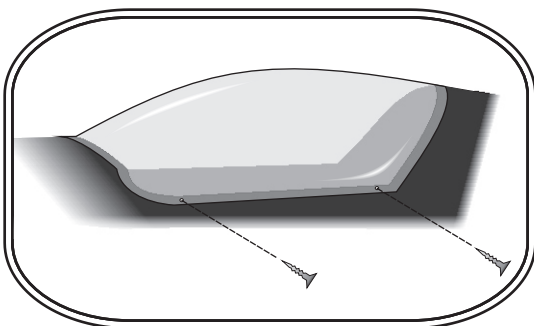
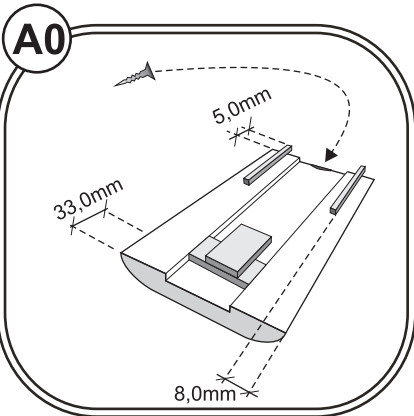
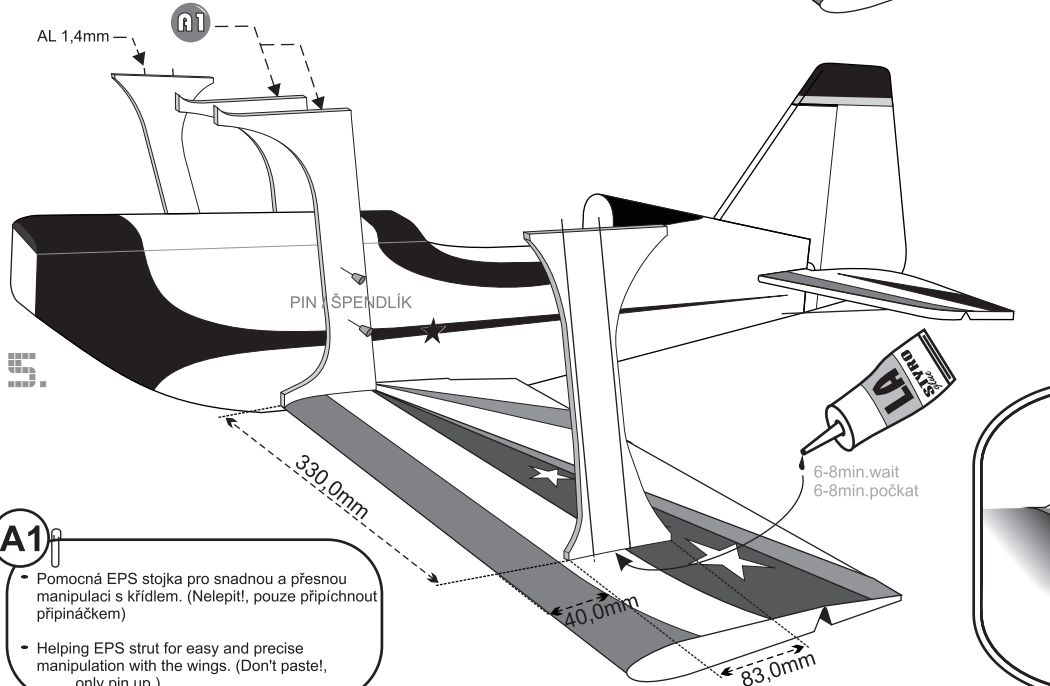
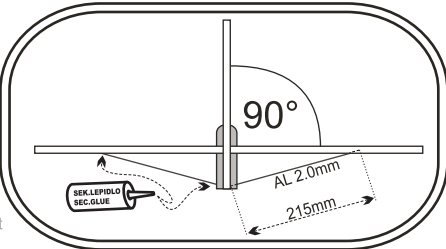
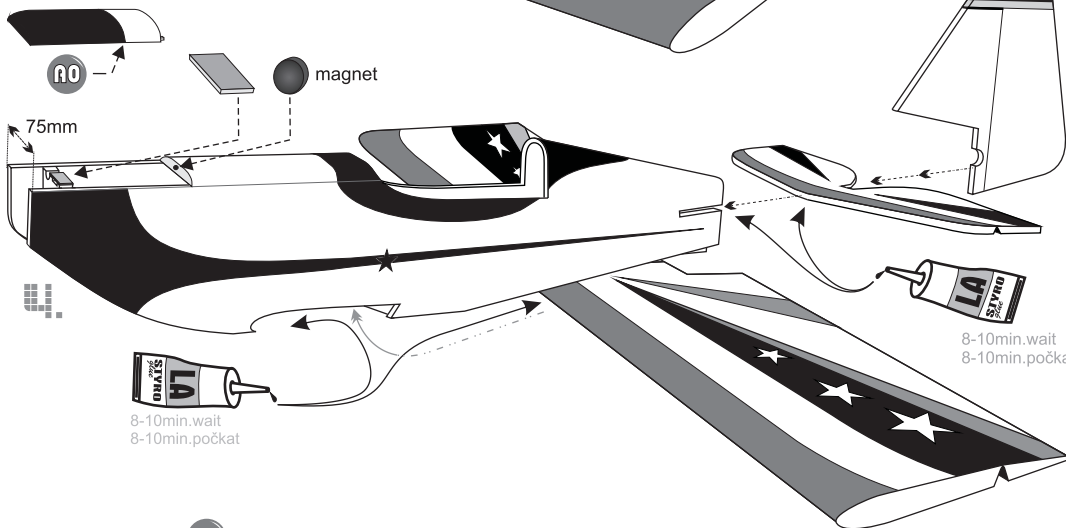

- A1**
- Pomocná EPS stojka pro snadnou a přesnou manipulaci s křídlem. (Nelepít!, pouze připínáčkem)
  - Helping EPS strut for easy and precise manipulation with the wings. (Don't paste!, only pin up)

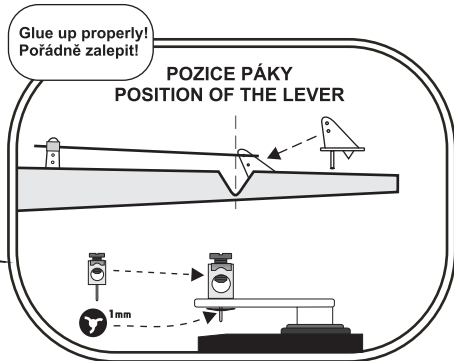
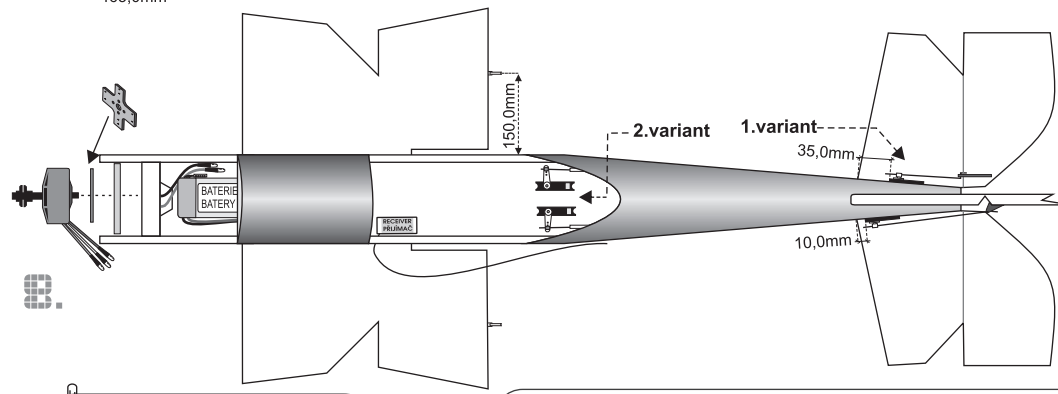
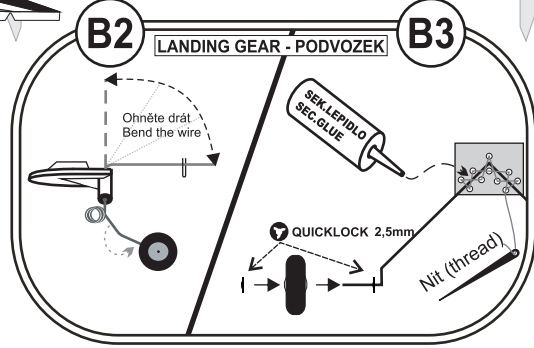
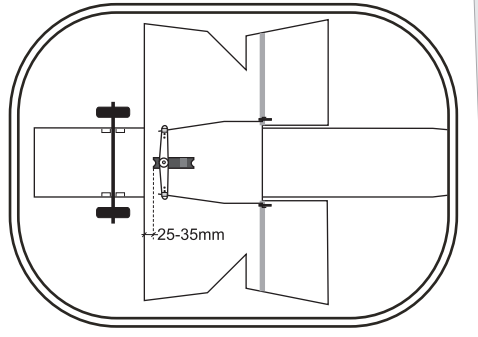
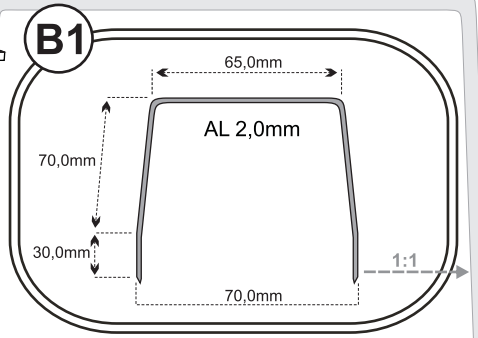
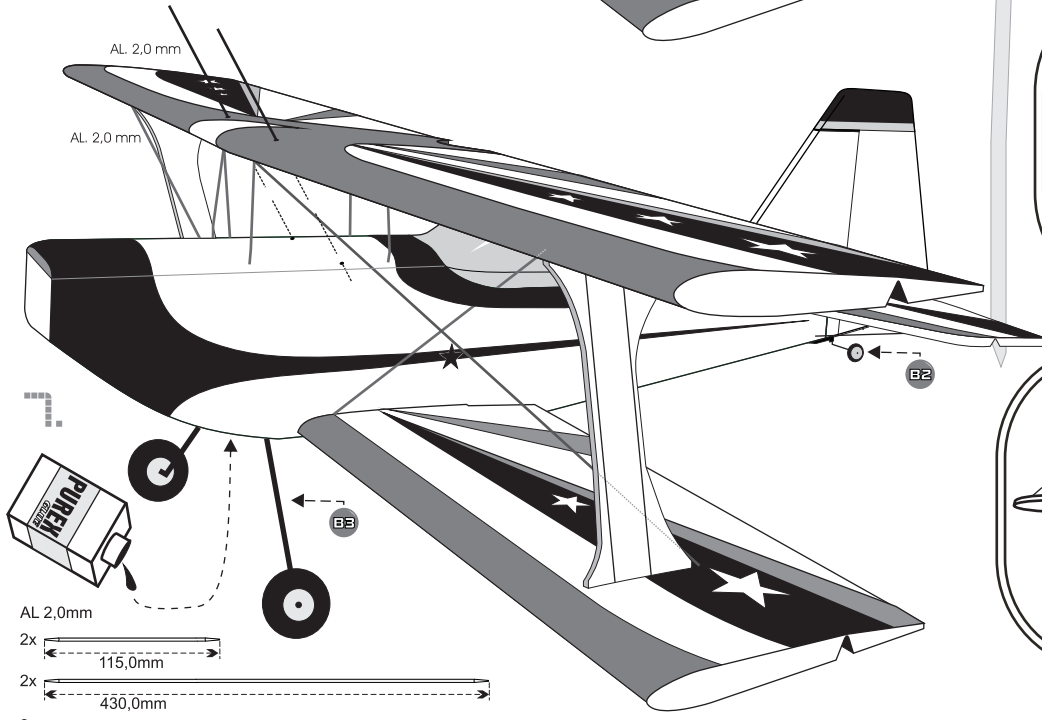
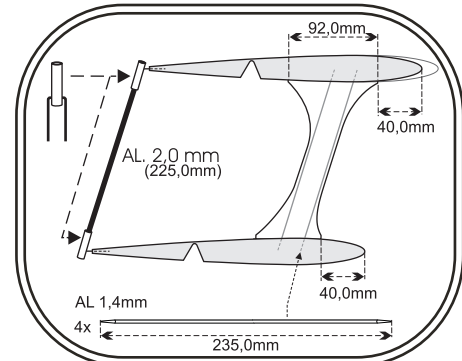
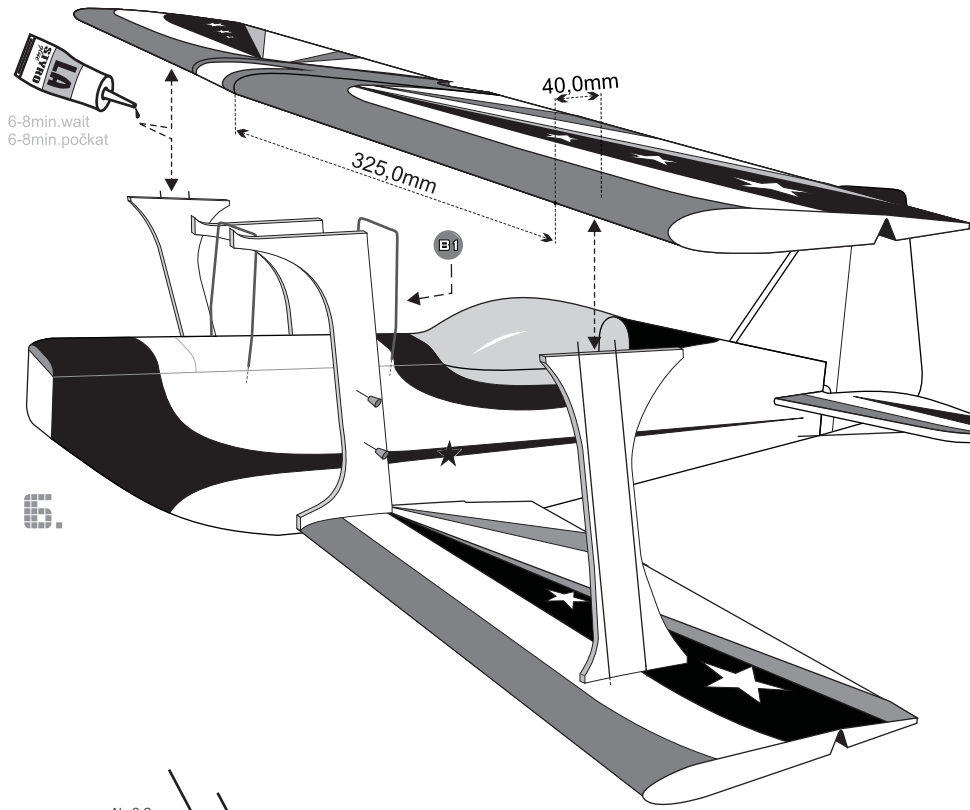

• Těžiště modelu je 30-40 mm od náběžné hrany spodního křídla (pro začínající piloty), pokročilí mohou těžiště posouvat k hodnotě 45-55mm. Výchylky doporučujeme nastavit dle vlastních letových zkušeností, nejméně však +/- 15%.

• Center of gravity position is 30-40mm on the lower wing (for beginners), 45-55 mm possible for advanced pilots. We recommend to adjust the deflection of the control surface-aileron and empennage according to one's own habits and experience, however they should be at least +/- 15 degrees.

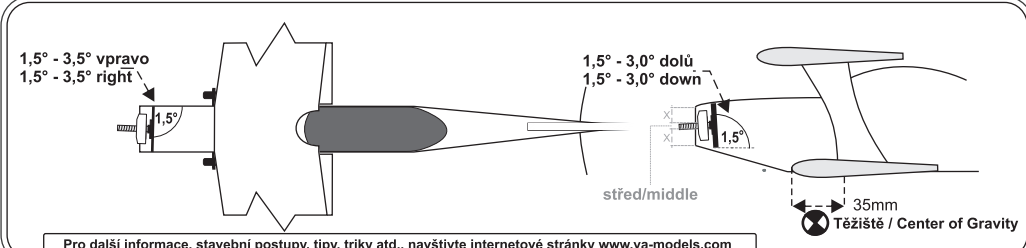

Pro další informace, stavební postupy, tipy, triky atd., navštivte internetové stránky [www.va-models.com](http://www.va-models.com)  
 For more informations, build methods, tips and tricks etc., please, visit our website [www.va-models.com](http://www.va-models.com)